

WatchGuard AP430CR Hardware Guide

The WatchGuard AP430CR is designed for indoor or rugged outdoor deployment conditions and built with an industrial-rated IP67 enclosure.

The AP430CR features an 802.11ax 2x2 2.4 GHz dual radio and 4x4 5 GHz dual concurrent radio that supports up to 1148 Mbps data rate on the 2.4 GHz band and 2402 Mbps on the 5 GHz band.



The AP430CR also has a third 2x2 dual band radio for security scanning, and an integrated Bluetooth (BLE) radio.

Power is provided by a PoE+ (Power over Ethernet) power source.

Access Point Management

You can manage the AP430CR with WatchGuard Cloud. WatchGuard Cloud delivers a simplified platform for Wi-Fi management to easily deploy, configure, and report on your wireless networks.

For more information on how to set up your access point with WatchGuard Cloud, see watchguard.com/start.

About Your Hardware

Hardware Specifications

Hardware	Description
Processor	Qualcomm Hawkeye IPQ8071A-1 Quad-core A53s @1.0GHz, Enterprise chip with I-Temp support
Memory	<ul style="list-style-type: none"> ■ Flash: NOR Flash 8MB, NAND Flash 256MB ■ RAM: DDR4 512MB x 2
Radio Model	<ul style="list-style-type: none"> ■ 2.4 GHz Qualcomm Iron QCN5124-1 2x2 i-temp radio ■ 5 GHz Qualcomm Iron QCN5154-1 4x4 i-temp radio ■ Scan radio: Qualcomm QCA9892 i-temp dual band 11ac 2x2 radio ■ Bluetooth: Qualcomm CSR8811A12 Bluetooth 4.0
Radio Type and Frequency Band	<ul style="list-style-type: none"> ■ Radio 1: 2.4 GHz 2x2 802.11b/g/n/ax ■ Radio 2: 5 GHz 4x4 802.11a/n/ac/ax ■ Radio 3 (Scan): Dual band 802.11ac 2x2 radio
Antennas	<ul style="list-style-type: none"> ■ Wi-Fi: 4 x 4/5dBi 2.4/5 GHz dual band N-type omnidirectional antennas ■ Scan Radio: 2 x 4/5dBi 2.4/5 GHz dual band N-type omnidirectional antennas ■ BLE: 1 x 4dBi 2.4 GHz external antenna <p>WatchGuard dual band omnidirectional dipole antennas (WG9004) are sold separately in packs of two antennas.</p> <p>Note: The device must have antennas connected for full range and functionality.</p>
Ethernet Interfaces	<ul style="list-style-type: none"> ■ 1 x 5 GbE Ethernet port (Aquantia AQR114C) ■ 1 x GbE Ethernet port (QCA AR8033)
Power Interface	PoE 54V DC 802.3at
Power Consumption	25.44W
MTBF (Mean Time Between Failures)	151,258 hours at 25 °C / 77 °F

Hardware	Description
Dimensions	267.1 mm x 217.65 mm x 53.7 mm (10.5" x 8.6" x 2.1")
Weight	1.759 kg (3.87 lbs)

Environmental Requirements

To safely install your WatchGuard access point, we recommend that you:

- Install the device per local regulations
- Make sure the device has adequate clearance for air flow and cooling

Other environmental requirements:

Operating Temperature	-30°C to 60°C (-22°F to 140°F)
Operating Humidity	5% to 95% non-condensing
Non-operating Temperature	-40°C to 85°C (-40°F to 185°F)
Non-operating Humidity	5% to 95%, non-condensing

Hardware Description



Bottom Panel Connections

2.4/5GHz

Antenna connectors for the dual band Wi-Fi radios.

2.4/5GHz Scan

Antenna connector for the dual band security scanning radio.

LAN 1 (POE+)

The LAN 1 port is a 5 GbE port that connects the access point to a wired LAN connection through a switch or hub. This port also provides PoE+ (802.3at) power for the access point.

LAN 2

The LAN 2 port is a 1 GbE LAN port that you can use as a wired extension for an SSID network.

Reset Button

The reset button is located above the LAN 2 port. You must remove the weatherproof connector to access the LAN 2 port and the reset button.

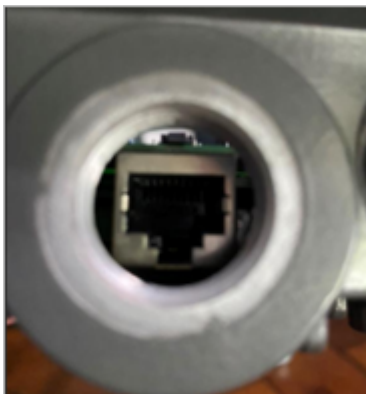

To reset the access point to factory-default settings:

- Remove the weatherproof connector from the LAN 2 port.
- Use a paper clip or other small object to press the reset button above the LAN 2 port.
- Press and hold the reset button for up to 10 seconds. When you release the reset button, all LEDs will go off to indicate that the access point has rebooted.

Top Panel Connections



5GHz/BLE

Antenna connector for the 5 GHz Wi-Fi and Bluetooth (BLE) radio.

2.4/5GHz Scan

Antenna connector for the dual band security scanning radio.

5GHz

Antenna connector for the 5 GHz Wi-Fi radio.

Side Panel Connections

LED Indicators



The access point has LED indicators that can show status conditions for the device connection to WatchGuard Cloud. The LED indicator status depends on the firmware version on the device.

[Access Point Firmware 1.1.7-0 and Higher](#)

[Access Point Firmware 1.1.4-0 and Lower](#)

Current factory default access points ship with firmware version 1.1.4-0 or lower.

Mount and Connect the Access Point

Your package includes these wall mount and pole mount accessories:

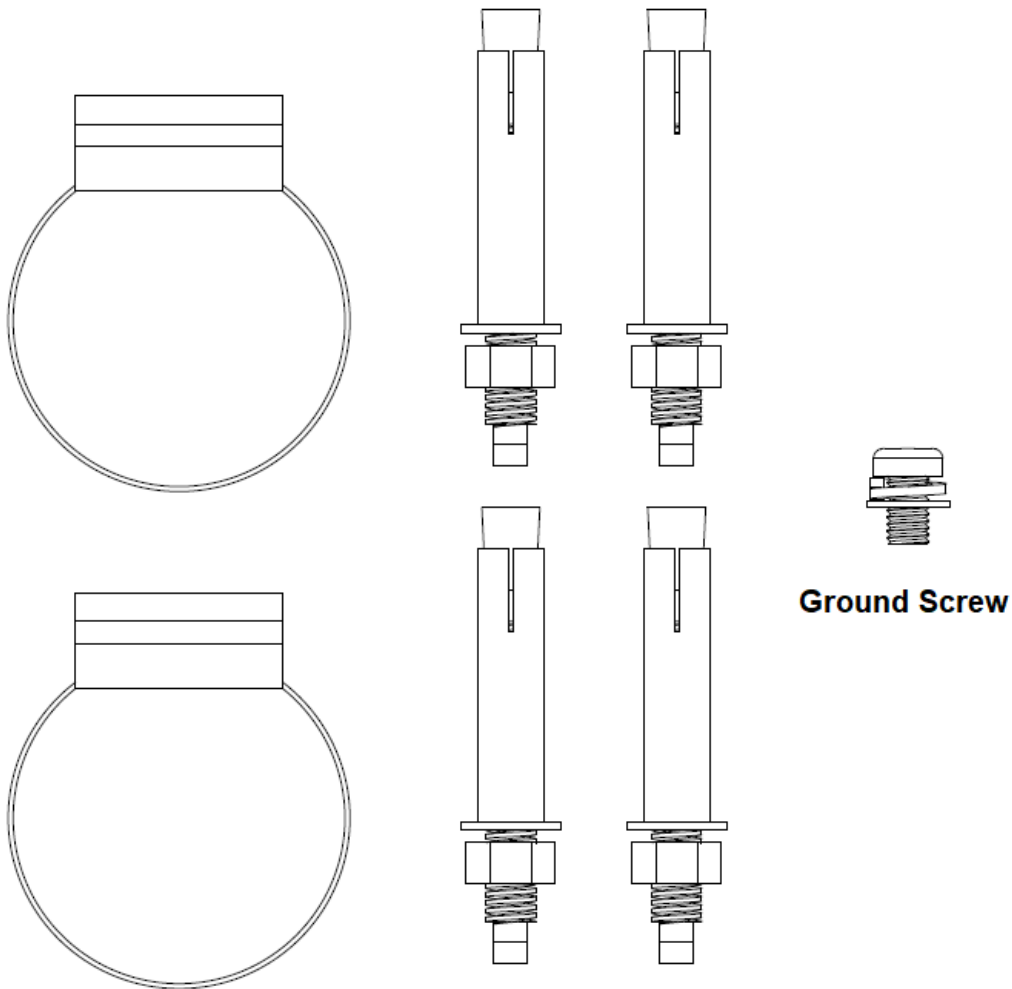

Pole Mount Clamps

Wall Mount Screws

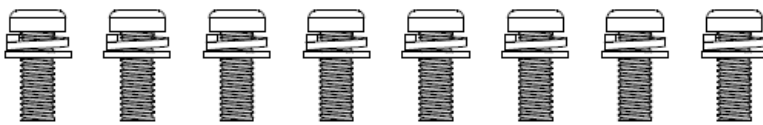

Wall and Pole Mount Screws

- 2 x Pole mount clamps
- 4 x Wall mount screws
- 8 x Wall and pole mount screws
- Ground screw

The MAC address and serial number of your access point are printed on a label on the back of the device. Make sure you record this information before you mount the device.

Wall Mount Installation

Use the supplied wall-mounting accessories to install the access point on a wall.

1. Attach the access point to the wall mount bracket with the included screws.
2. Affix the access point and mounting bracket to the wall with the included screws.

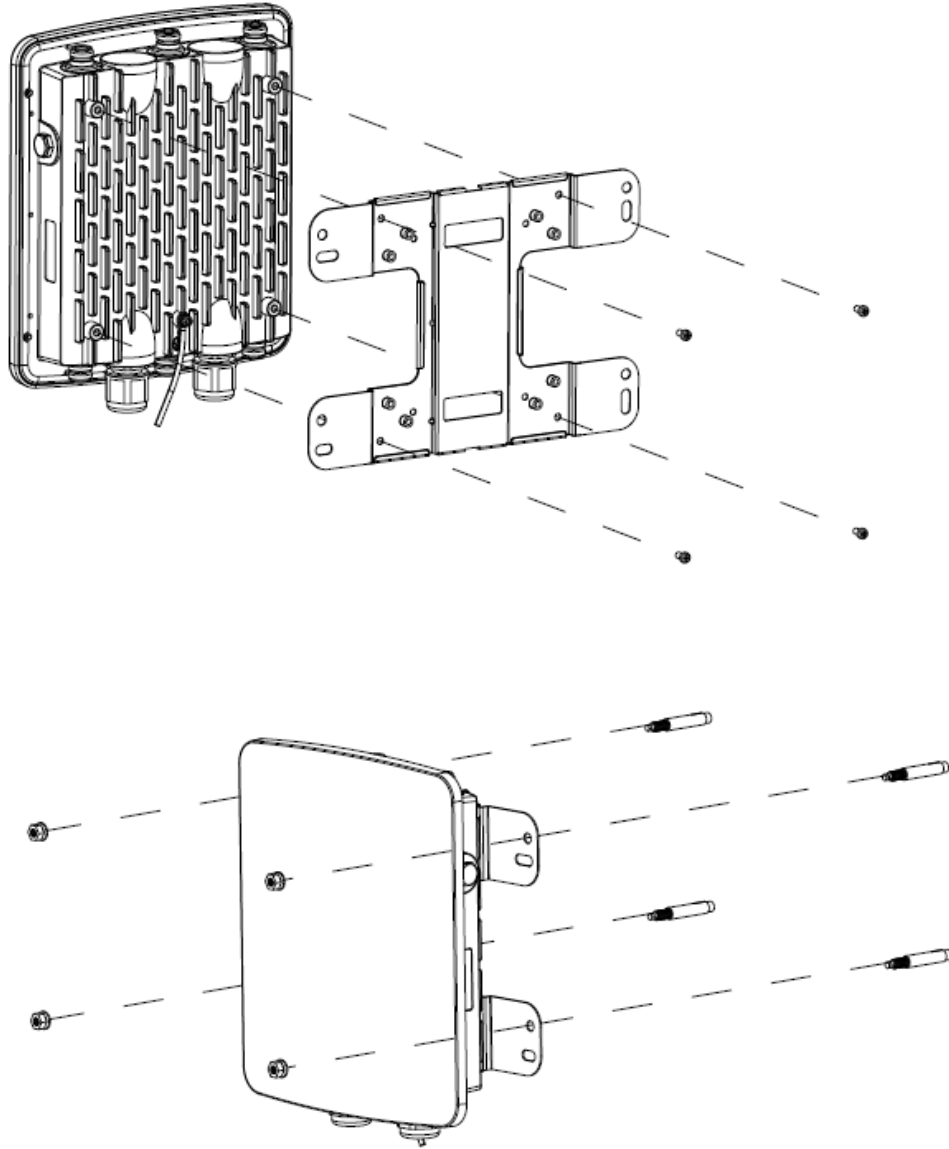

Pole Mount Installation

Use the supplied pole-mounting accessories to install the access point on a pole.

1. Attach the wall mount bracket to the access point with the included screws.
2. Attach the pole mount bracket to the wall mount bracket and access point with the included screws.
3. Place the access point on the pole.
4. Insert the clamps in the slots on the pole mount bracket and wrap around the pole.
5. Fasten the screws and make sure the access point is firmly attached to the pole.

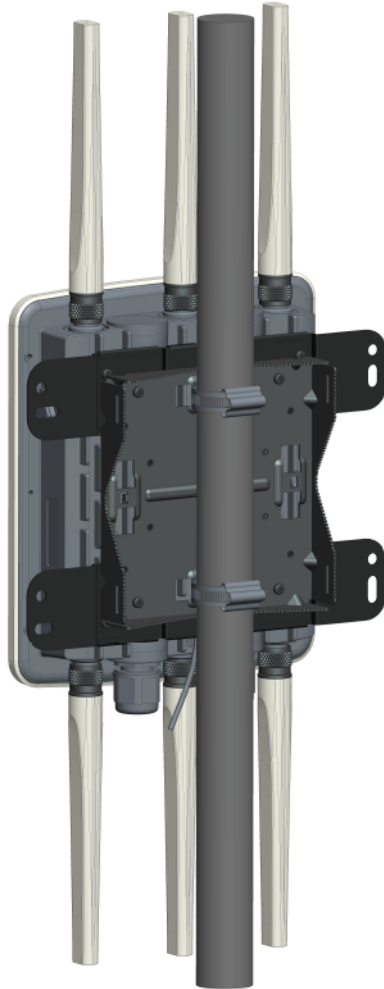
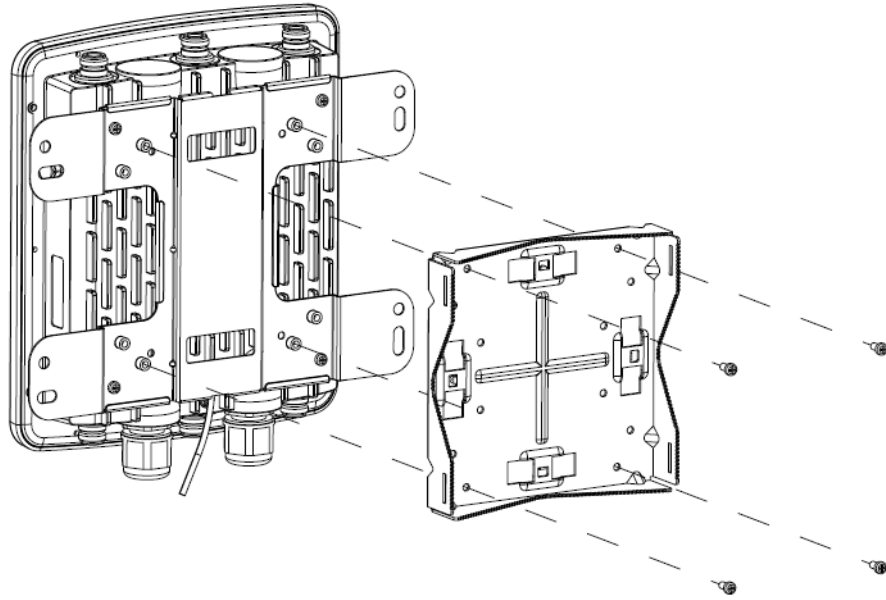

Antenna Installation

WatchGuard dual band omnidirectional dipole antennas (WG9004) are sold separately in packs of two antennas.

The device must have antennas connected for full range and functionality.



- The access point requires a total of six antennas (two antennas for each radio band, and two antennas for the dual band scanning radio).
- On the top of the access point, there are two N-type connectors for the 2.4/5 GHz dual-band radios, and one connector for the scanning radio.
- On the bottom of the access point, there are two N-type connectors for the 5 GHz radios, and one connector for the scanning radio.

Insert the antennas into the connectors for each radio and turn clockwise to tighten.

You can use WatchGuard omnidirectional antennas or other third-party omnidirectional and directional antennas based on your deployment requirements. If you use other third-party antenna types, you are responsible for verifying compliance with regional-based regulations based on these peak gain values.

2.4 GHz			
Frequency (MHz)	2400	2450	2500
Peak Gain (dBi)	5.1	5.0	5.5
Efficiency (%)	78.3	76.4	83.2

5 GHz									
Frequency (MHz)	4900	5150	5250	5350	5450	5550	5650	5750	5850
Peak Gain (dBi)	6.1	6.5	6.4	6.7	7.2	6.6	6.6	7.0	6.9
Efficiency (%)	74.6	74.1	78.6	79.2	77.9	79.3	79.4	83.8	78.2

Connect the Ground Wire

To make sure your access point is safely protected from electrical events, we recommend you ground the access point according to your local regulations.

Use the included screw to attach a ground wire to the ground connector on the back of the access point and to a nearby grounding point.

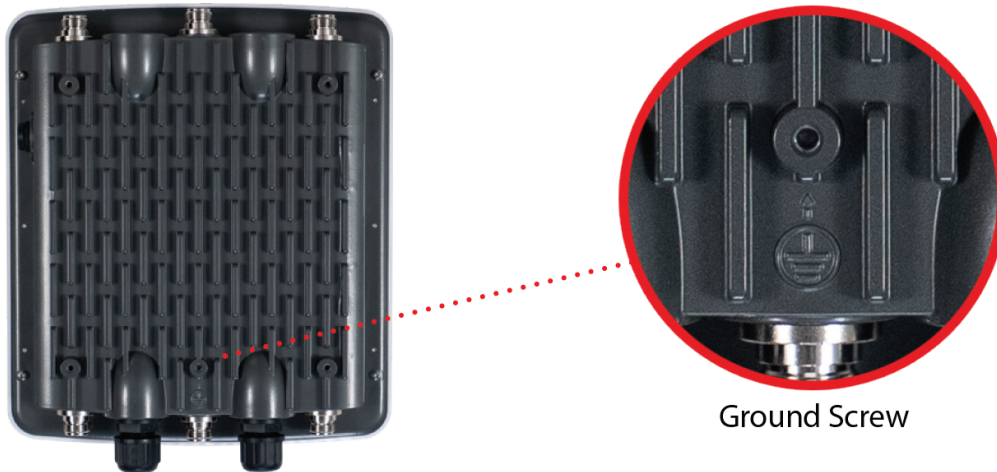

Connect the Access Point

Plug one end of the Ethernet cable from your network into the LAN 1 (PoE+) port on the bottom panel of the access point.

Make sure the other end of the Ethernet cable is connected to your network through a hub, switch, or injector with PoE+ (802.3at) power enabled.



Access Point connected to PoE+ injector



Access Point connected to switch with PoE+ power

How to Assemble the Weatherproof Connector

Use these instructions to connect the Ethernet cable to the access point through the weatherproof connector.

1

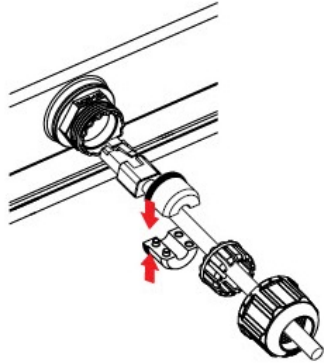

2

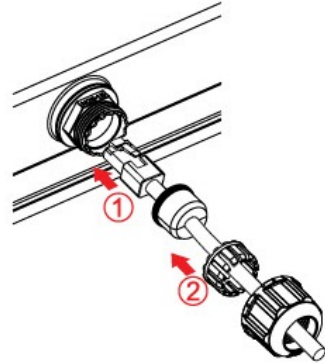

3

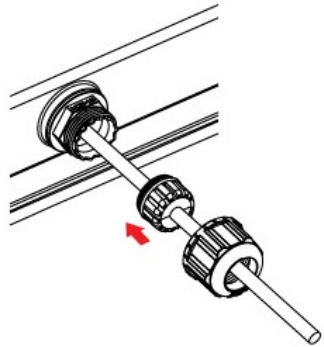

4

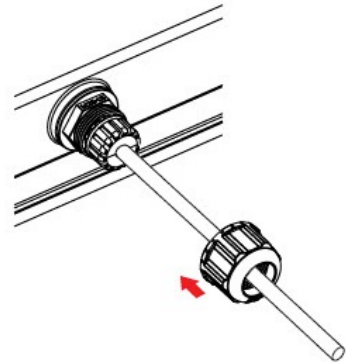

5

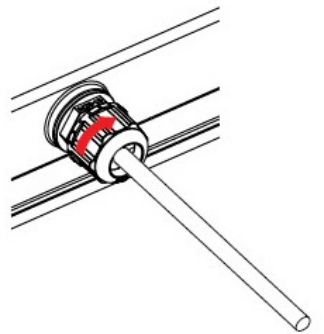

How to Disassemble the Weatherproof Connector

Use these instructions to disconnect the Ethernet cable from the weatherproof connector.

1

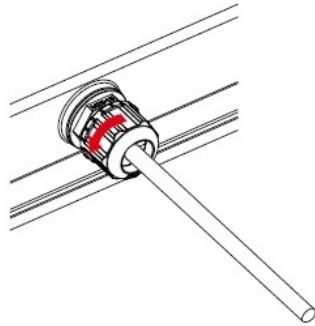

2

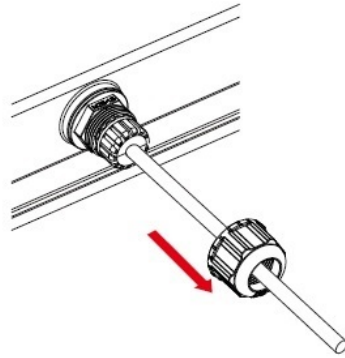

3

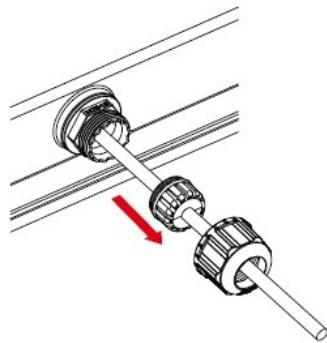

4

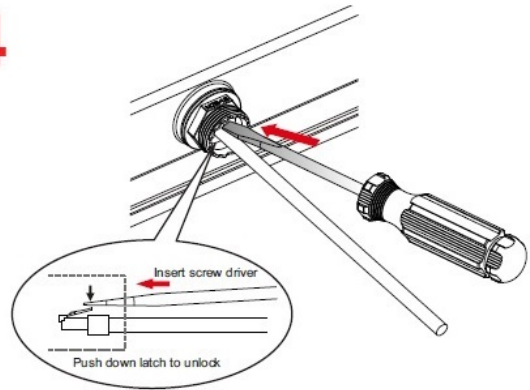

5

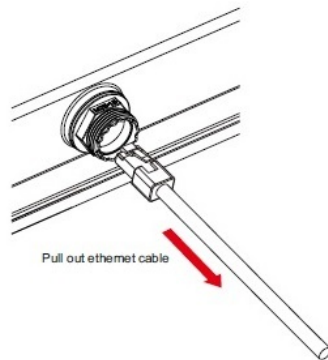

Ethernet Power Injector (Optional)

You can power the access point with an optional Ethernet Power Injector. The PoE+ power injector enables you to power the access point through an existing Ethernet connection. With this device, you do not have to position your access point near a power outlet.



This device complies with IEEE 802.3at/af PoE specifications. Do not use any PoE adapters that are not IEEE 802.3at/af compliant as they may damage your device.

To connect an Ethernet Power Injector to the WatchGuard access point:

1. Plug the Ethernet Power Injector into an AC power source.
2. Connect an Ethernet cable from your network backbone (for example, a PoE-capable router, switch, or hub) to the **LAN** connector on the Ethernet Power Injector.
3. Connect an Ethernet cable from the **LAN1 PoE** Ethernet interface on the access point to the **PoE** connector on the Ethernet Power Injector.

The table provides the specifications for the power adapter.

Ethernet Power Injector Specs	
WatchGuard Part Number	802.3at PoE+ Injector with AC cord (US/FCC) (WG8599) 802.3at PoE+ Injector with AC cord (CE) (WG8600) 802.3at PoE+ Injector with AC cord (UK) (WG8601) 802.3at PoE+ Injector with AC cord (AUS) (WG8602)
Specification	IEEE 802.3at/af
AC Input Voltage Rating	100-240VAC
Input Current	0.8A max for 100VAC

Ethernet Power Injector Specs	
Output Power	30W maximum
Ethernet Interfaces	LAN: RJ-45 for 10/100/1000/2500 Mbps data POE: RJ-45 for 10/100/1000/2500 Mbps data and power Voltage: Pin4, 5:54V, Pin7, 8:Return
Indicator	Power: Green
Temperature	Operating: 0 - 40°C (32 - 104°F) Storage: -30 - 80°C (-22 - 176°F)
Humidity	5% - 90% (Operating and storage)
Dimensions	L = 99 mm (3.9") W = 68.5 mm (2.27") H = 33 mm (1.3")
Weight	149.6 g (0.33 lbs)

Notices

All WatchGuard products are designed and tested to meet strict safety requirements. These requirements include product safety approvals and other global compliance standards. Please read these instructions carefully before operating the product, and refer to them as needed to ensure the continued safe operation of your product.

For patent information, please visit <http://www.watchguard.com/patents>

Safety Warning

If protective earthing is used as a safeguard, the instructions shall require connection of the equipment protective earthing conductor to the installation protective earthing conductor (for example, by means of a power cord connected to a socket-outlet with earthing connection). To meet safety and electromagnetic interference (EMI) requirements, you must make sure the power source is connected to earth ground before you connect power to the access point.

FCC Certification

This device complies with part 15 of the FCC Rules. Operation is subject to the following two conditions: (1) This device may not cause harmful interference, and (2) this device must accept any interference received, including interference that may cause undesired operation.

This equipment has been tested and found to comply with the limits for a Class B digital device, pursuant to part 15 of the FCC Rules. These limits are designed to provide reasonable protection against harmful interference in a residential installation.

This equipment generates, uses and can radiate radio frequency energy and, if not installed and used in accordance with the instructions, may cause harmful interference to radio communications. However, there is no guarantee that interference will not occur in a particular installation. If this equipment does cause harmful interference to radio or television reception, which can be determined by turning the equipment off and on, the user is encouraged to try to correct the interference by one or more of the following measures:

- Reorient or relocate the receiving antenna.
- Increase the separation between the equipment and receiver.
- Connect the equipment into an outlet on a circuit different from that to which the receiver is connected.
- Consult the dealer or an experienced radio/TV technician for help.

FCC Caution: Any changes or modifications not expressly approved by the party responsible for compliance could void the user's authority to operate this equipment.

This transmitter must not be co-located or operating in conjunction with any other antenna or transmitter.

This device meets all the other requirements specified in Part 15E, Section 15.407 of the FCC Rules.

Radiation Exposure Statement:

This equipment complies with FCC radiation exposure limits set forth for an uncontrolled environment. This equipment should be installed and operated with minimum distance 40cm between the radiator & your body.

CE Notice

The CE symbol on your WatchGuard Technologies equipment indicates that it is in compliance with the Electromagnetic Compatibility (EMC) directive and the Low Voltage Directive (LVD) of the European Union (EU).



Industry Canada Certification

This device complies with ISED's licence-exempt RSSs. Operation is subject to the following two conditions: (1) This device may not cause harmful interference, and (2) this device must accept any interference received, including interference that may cause undesired operation.

Le présent appareil est conforme aux CNR d'ISED applicables aux appareils radio exempts de licence. L'exploitation est autorisée aux deux conditions suivantes: (1) le dispositif ne doit pas produire de brouillage préjudiciable, et (2) ce dispositif doit accepter tout brouillage reçu, y compris un brouillage susceptible de provoquer un fonctionnement indésirable.

Caution

For devices with detachable antenna(s), the maximum antenna gain permitted for devices in the bands 5250-5350 MHz and 5470-5725 MHz must be such that the equipment still complies with the e.i.r.p. limit.

For devices with detachable antenna(s), the maximum antenna gain permitted for devices in the band 5725-5850 MHz must be such that the equipment still complies with the e.i.r.p. limits as appropriate.

For systems that are capable of operating outdoors or with antennas mounted outdoors (where applicable antenna type(s), antenna model(s), and worst-case tilt angle(s)) are necessary to remain compliant with the e.i.r.p, therefore, the elevation mask requirement set forth in section 6.2.2.3 should be clearly indicated.

Avertissement

Pour les appareils avec antenne(s) amovible(s), le gain d'antenne maximal autorisé pour les appareils dans les bandes 5250-5350 MHz et 5470-5725 MHz doit être tel que l'équipement soit toujours conforme à la e.i.r.p. limite.

Pour les appareils avec antenne(s) amovible(s), le gain d'antenne maximal autorisé pour les appareils dans la bande 5725-5850 MHz doit être tel que l'équipement soit toujours conforme à la p.i.r.e. limites le cas échéant.

Lorsqu'il y a lieu, les types d'antennes (s'il y en a plusieurs), les numéros de modèle de l'antenne et les pires angles d'inclinaison nécessaires pour rester conforme à l'exigence de la p.i.r.e. applicable au masque d'élévation, énoncée à la section 6.2.2.3, doivent être clairement indiqués

Radiation Exposure Statement

This equipment complies with ISED radiation exposure limits set forth for an uncontrolled environment. This equipment should be installed and operated with minimum distance 42cm between the radiator & your body.

Déclaration d'exposition aux radiations

Cet équipement est conforme aux limites d'exposition aux rayonnements ISED établies pour un environnement non contrôlé. Cet équipement doit être installé et utilisé avec un minimum de 42cm de distance entre la source de rayonnement et votre corps.

EU Declaration of Conformity

This device complies with the essential requirements of the RED Directive 2014/53/EU. The following test methods have been applied in order to prove presumption of conformity with the essential requirements of the RED Directive 2014/53/EU:

EN 62368-1:2014+A11:2017

Safety of Information Technology Equipment (ITE)

EN 55024:2010+A1:2015

Immunity for Information Technology Equipment (ITE)

EN 55032:2015+A11:2020

Electromagnetic compatibility of multimedia equipment - Emission requirements.

EN 55035: 2017/A11:2020

Electromagnetic compatibility of multimedia equipment — Immunity Requirements

EN 61000-3-2:2014

Limits for harmonic current emissions.

EN 61000-3-3:2013

Limitation of voltage changes, voltage fluctuations and flicker in public low-voltage supply systems, for equipment with rated current ≤ 16 A per phase and not subject to conditional connection.

EN 62311:2008

Assessment of electronic and electrical equipment related to human exposure restrictions for electromagnetic fields (0 Hz - 300 GHz).

EN 301 489-1 V2.2.3

Electromagnetic compatibility and Radio spectrum Matters (ERM); Electro Magnetic Compatibility (EMC) standard for radio equipment and services; Part 1: Common technical requirements

EN 301 489-17 V3.1.1

Electromagnetic compatibility and Radio spectrum Matters (ERM); ElectroMagnetic Compatibility (EMC) standard for radio equipment; Part 17: Specific conditions for Broadband Data Transmission Systems

This device is a 5 GHz wideband transmission system (transceiver), intended for use in all EU member states and EFTA countries, except in France and Italy where restrictive use applies. In Italy the end-user should apply for a license at the national spectrum authorities in order to obtain authorization to use the device for setting up outdoor radio links and/or for supplying public access to telecommunications and/or network services.

This device may not be used for setting up outdoor radio links in France and in some areas the RF output power may be limited to 10 mW EIRP in the frequency range of 2454 - 2483.5 MHz. For detailed information the end-user should contact the national spectrum authority in France.

EN 300 328 V2.2.2

Electromagnetic compatibility and Radio spectrum Matters (ERM); Wideband transmission systems; Data transmission equipment operating in the 2.4 GHz ISM band and using wide band modulation techniques; Harmonized EN covering the essential requirements of article 3.2 of the RED Directive

EN 301 893 V2.1.1

Broadband Radio Access Networks (BRAN); 5 GHz high performance RLAN; Harmonized EN covering the essential requirements of article 3.2 of the RED Directive

EN 50385: 2017

This product standard is related to human exposure to radio frequency electromagnetic fields transmitted by base station equipment in the frequency range 110 MHz to 100 GHz.

Declaration of Conformity

WatchGuard Technologies Inc. hereby declares that the product(s) listed below conform to the European Union directives and standards identified in this declaration.

Product (s):

802.11 a/b/g/n/ac/ax Access Point, AP430CR

EU Directive(s):

Low Voltage (2014/35/EU)
Electromagnetic Compatibility (2014/30/EU)
Energy-related Products (2009/125/EC)
RoHS (2011/65/EU and 2015/863/EU RoHS)
WEEE Directive 2012/19/EU
The Radio Equipment Directive (2014/53/EU)

Common Standard(s):

EN 62368-1:2014+A11:2017	Safety for ITE
EN 55024:2010	
EN 55024:2010+A1:2015	Immunity for ITE
EN 55032:2015+A11:2020	
EN 55035:2017/A11:2020	
EN 61000-3-2:2014	Harmonics
EN 61000-3-3:2013	Flicker

Wireless Standard(s):

EN 62311:2008	
EN 301 489-1 v2.2.3 (2019-11)	EMC and Radio Spectrum Matters
EN 301 489-17 v3.1.1 (2017-02)	EMC and Radio Spectrum Matters
EN 300 328 v2.2.2 (2019-07)	Radio Spectrum Matters
EN 301 893 v2.1.1 (2017-05)	Broadband Radio Access Networks
EN 50385:2017	

This device complies with Directive 2014/53/EU issued by the Commission of the European Community.

Manufacturer / Hersteller: WatchGuard Technologies
505 5th Ave S. Suite 500, Seattle, WA 98104 USA Radio

Equipment / Funkanlage: 802.11 a/b/g/n/ac/ax Access Point
Type Designation / Typenbezeichnung: AP430CR
Specifications / Technische Daten: 802.11a,b,g,n,ac,ax (2.4Ghz & 5Ghz)
Intended Purpose / Verwendungszweck: Outdoor access point
Equipment Class / Betriebsmittel der Klasse: Class II
Operating temperature: -30° C to 60° C

The above device complies with the essential requirements and other relevant provisions to Directive 2014/53/EU when used for its intended purpose. This equipment may be operated in the USA, Canada, & Europe Union.

Warning! This is a Class B product. In a domestic environment this product may cause radio interference in which case the user may be required to take adequate measures.

Frequency range (MHz)	Max. Transmit Power (W)
Bluetooth	0.00794
WLAN Wi-Fi 802.11x; 2, 4 GHz	0.09418
WLAN Wi-Fi 802.11x; 5 GHz	0.86896

Restrictions: France (i) les dispositifs fonctionnant dans la bande 5150-5250 MHz sont réservés uniquement pour une utilisation à l'intérieur afin de réduire les risques de brouillage préjudiciable aux systèmes de satellites mobiles utilisant les mêmes canaux; (ii) De plus, les utilisateurs devraient aussi être avisés que les utilisateurs de radars de haute puissance sont désignés utilisateurs principaux (c.-à-d., qu'ils ont la priorité) pour les bandes 5 250-5 350 MHz et 5 650-5 850 MHz et que ces radars pourraient causer du brouillage et/ou des dommages aux dispositifs LAN-EL.

Die oben genannten Gerät entspricht den grundlegenden Anforderungen und anderen relevanten Bestimmungen der Richtlinie 2014/53/EU, wenn für den vorgesehenen Zweck verwendet werden. Dieses Gerät ist für die Verwendung in den USA, Kanada, and Europäische Union.

Warnung! Dies ist eine Einrichtung der Klasse B. Diese Einrichtung kann im Wohnbereich Funkstörungen verursachen. In diesem Fall kann vom Betreiber verlangt werden, angemessene Maßnahmen durchzuführen

Einschränkungen: Frankreich –(i)-Geräte, die im Band 5150-5250 MHz ist nur für den Innenbereich, um das Risiko von Störungen des mobilen Satelliten-Systeme, die die gleichen Kanäle (ii) Darüber hinaus reduzieren vorbehalten, sollten Benutzer auch darauf hingewiesen werden, dass die Nutzer von Hochleistungs-Radare bezeichnet werden primäre Benutzer (dh d. sie haben Priorität) der Bänder 5 250-5 350 MHz und 5 650-5 850 MHz und dass diese Radargeräte können Störungen und / oder Schäden an LE-LAN-Geräten verursachen.

Laurence Huang



Signature
Full Name: Laurence Huang
Position: Manufacturing Program Manager

Date: May 15, 2021

Brazil ANATEL

Este equipamento não tem direito à proteção contra interferência prejudicial e não pode causar interferência em sistemas devidamente autorizados.

CISPR 22 Statement

Este produto não é apropriado para uso em ambientes domésticos, pois poderá causar interferências eletromagnéticas que obrigam o usuário a tomar medidas necessárias para minimizar estas interferências.

This is a class A product. In a domestic environment, this product may cause radio interference in which case the user may be required to take adequate measures.

Mexico NOM

La operación de este equipo está sujeta a las siguientes dos condiciones:

(1) es posible que este equipo o dispositivo no cause interferencia perjudicial y

(2) este equipo o dispositivo debe aceptar cualquier interferencia, incluyendo la que pueda causar su operación no deseada.

Japan Statement

この装置には、電波法に基づく技術規則適合証明書の認定を受けた特定の無線装置が含まれています。

This equipment contains specified radio equipment that has been certified to the Technical Regulation Conformity Certification under Radio Law.

Japan VCCI Class B Statement

この装置は、クラス B 情報技術装置です。この装置は、住宅環境で使用することを目的としていますが、この装置がラジオやテレビジョン受信機に近接して使用されると、受信障害を引き起こすことがあります。取扱説明書に従って正しい取り扱いをして下さい。VCCI-B

Taiwan NCC Statement

取得審驗證明之低功率射頻器材，非經核准，公司、商號或使用者均不得擅自變更頻率、加大功率或變更原設計之特性及功能。

低功率射頻器材之使用不得影響飛航安全及干擾合法通信；經發現有干擾現象時，應立即停用，並改善至無干擾時方得繼續使用。前述合法通信，指依電信管理法規定作業之無線電通信。低功率射頻器材須忍受合法通信或工業、科學及醫療用電波輻射性電機設備之干擾。

1. 使用此產品時應避免影響附近雷達系統之操作。

〔本產品電磁波曝露量(MPE)標準值 $1\text{mW}/\text{cm}^2$ ，送測產品實測值為 $0.571\text{mW}/\text{cm}^2$ ，建議使用時至少距離人體 23cm 〕

[警語內容]

本器材須經專業工程人員安裝及設定，始得設置使用，且不得直接販售給一般消費者。

RoHS Statement

The member states of the European Union approved directive 2002/95/EC, Restrictions of Hazardous Substances (“RoHS directive”) that became valid on July 1, 2006. It states that all new electrical and electronic equipment put on the market within the member states must not contain certain hazardous materials. This device complies with the European Union’s R0HS directive 2002/95/EC and similar regulations that may be adopted by other countries for European Sales.

WEEE Statement

WEEE is a general set of requirements dictated in the EU Directive 2002/96/EC. This Directive mandated that member EU countries enact regulations governing the Waste of Electrical and Electronic Equipment (WEEE). The Directive, and its individual transpositions into specific country laws and legislation, is aimed at the reduction of WEEE through reuse, recovery, and recycling of WEEE.

WatchGuard is working in partnership with our European Union (EU) distribution partners to ensure that our products are in compliance with the WEEE statutes, and that the recovery of our product per the specific EU country legislative requirements is seamless for our product’s end users. If you have a WatchGuard product that is at its end of life and needs to be disposed of, please contact WatchGuard Customer Care Department at:

U.S. Customers: 877.232.3531

International Customers: +1.206.613.0456

WatchGuard is reasonably confident that our products do not contain any substances or hazardous materials presently banned by any legislation, and do not present a risk due to hazardous materials. WEEE recovery professionals should also note that these products do not have any materials that are of particular high value in their individual form.

REACH Certificate of Compliance

The new EU chemicals policy REACH (Registration, Evaluation, Authorization and restriction of Chemicals) came into effect on June 1, 2007. REACH is Europe's new chemicals legislation, which is applicable in all 27 EU Member States as well as the EFTA European Economic Area (EEA). REACH creates a new system for gathering information, assessing risks to human health and the environment, and authorizing or restricting the marketing and use of chemicals produced or supplied in the EEA. REACH has an impact on EEA producers and importers of finished products and users of chemicals in the course of industrial or professional activities.

WatchGuard supports the overall REACH objective of improving the protection of human health and the environment and will meet all applicable REACH requirements. WatchGuard is strongly committed to working with our customers and supply chain to define and implement the REACH requirements and ensure a smooth transition to compliance.

One of the REACH requirements is that manufacturers and importers have the duty to register substances they are producing or importing. In accordance with the regulations, the products of WatchGuard do not need to be registered for the following reasons:

- WatchGuard does not import more than 1 metric ton per year of a substance as defined by REACH.
- WatchGuard products are non-chemical products that are not designed to release any substance under normal and reasonably predictable application.
- Our products do not contain the listed substances at more than 0.1% by weight of the whole product/part.

[Give Us Feedback](#) • [Get Support](#) • [All Product Documentation](#) • [Technical Search](#)

© 2022 WatchGuard Technologies, Inc. All rights reserved. WatchGuard and the WatchGuard logo are registered trademarks or trademarks of WatchGuard Technologies in the United States and other countries. Various other trademarks are held by their respective owners.

